



**THIS DOCUMENT WAS OBTAINED FROM 'THE MUFON ARCHIVE' IN THE BLACK VAULT ENCYCLOPEDIA PROJECT.  
THIS SECTION IS A JOINT EFFORT BETWEEN THE MUTUAL UFO NETWORK (MUFON) AND THE BLACK VAULT  
TO OFFER AN UNPRECEDENTED FREE RESOURCE FOR UFO HISTORICAL RESEARCH.**

**PART OF THE BLACK VAULT INTERNET ARCHIVE, YOU CAN CHECK IT OUT AT:**

**[HTTP://WWW.THEBLACKVAULT.COM/ENCYCLOPEDIA](http://www.theblackvault.com/encyclopedia)**

**ALSO, VISIT MUFON FOR THE LARGEST PRIVATE ORGANIZATION DEDICATED TO THE STUDY OF UFOS  
FOR THE BENEFIT OF HUMANITY:**

**[HTTP://WWW.MUFON.COM](http://www.mufon.com)**

# THE MUFON UFO JOURNAL

NUMBER 151

SEPTEMBER 1980

Founded 1967

\$1.50

OFFICIAL PUBLICATION OF



MUTUAL UFO NETWORK, INC.

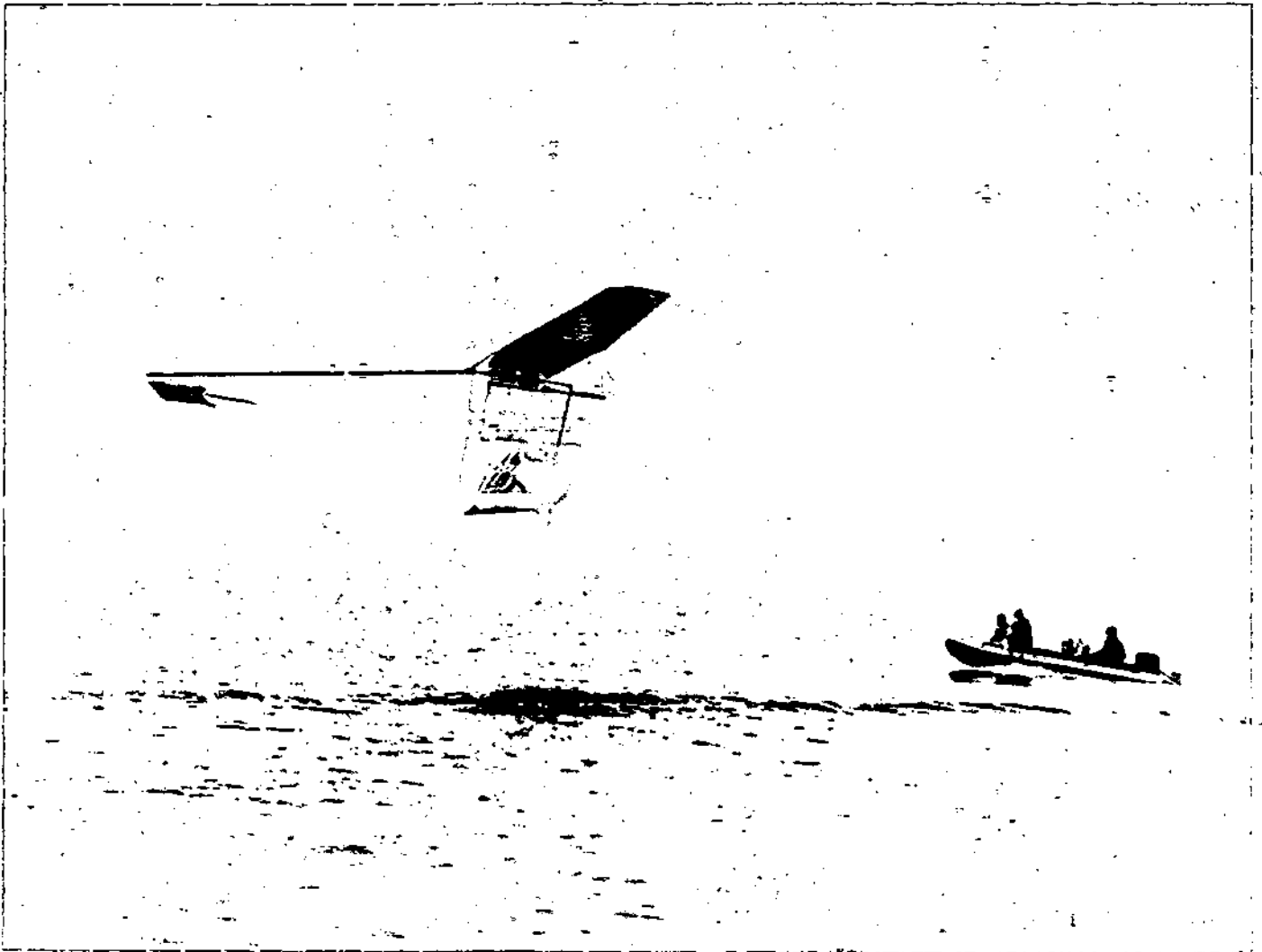

**Human-powered "Gossamer Albatross"; concept has received NASA research support for future extreme altitude aircraft (NASA photo)**

*The MUFON*  
**UFO JOURNAL**  
 (USPS 002-970)  
 103 Oldtowne Rd.  
 Seguin, Texas 78155

**RICHARD HALL**  
 Editor

**ANN DRUFFEL**  
 Associate Editor

**LEN STRINGFIELD**  
 Associate Editor

**MILDRED BIESELE**  
 Contributing Editor

**WALTER H. ANDRUS**  
 Director of MUFON

**TED BLOECHER**  
**DAVE WEBB**  
 Co-Chairmen,  
 Humanoid Study Group

**PAUL CERNY**  
 Promotion/Publicity

**REV. BARRY DOWNING**  
 Religion and UFOs

**LUCIUS FARISH**  
 Books/Periodicals/History

**MARK HERBSTTRIT**  
 Astronomy

**ROSETTA HOMES**  
 Promotion/Publicity

**TED PHILLIPS**  
 Landing Trace Cases

**JOHN F. SCHUESSLER**  
 UFO Propulsion

**DENNIS W. STACY**  
 Staff Writer

**NORMA E. SHORT**  
**DWIGHT CONNELLY**  
**DENNIS HAUCK**  
 Editor/Publishers Emeritus

The MUFON UFO JOURNAL is published by the Mutual UFO Network, Inc., Seguin, Texas. Membership/Subscription rates: \$15.00 per year in the U.S.A.; \$16.00 foreign. Copyright 1980 by the Mutual UFO Network. Second class postage paid at Seguin, Texas. POSTMASTER: Send form 3579 to advise change of address to The MUFON UFO JOURNAL, 103 Oldtowne Rd., Seguin, Texas 78155.

# FROM THE EDITOR

With this issue we pass the mark of 150 consecutive publications of the Journal (and its predecessor "Skylook"), an accomplishment of some note. As our International Director will confirm, it has not always been easy. Inflation, constantly rising costs of paper and printing, postal increases, and other factors have led to subscription price increases.

On top of all this — after recently priding ourselves on a good record of on-time publication — circumstances beyond our control have put us behind schedule temporarily. Please bear with us; we are taking all steps necessary to get back on schedule and to continue upgrading the quality of articles and news reporting. I have been personally gratified by the friendly and supportive comments of the readers, but critical comments also would be helpful.

With a continuing "Mutual" effort, we will strive to make the Journal a valuable source of information, opinion, discussion, and critical evaluation. Your participation in this process is important.

## In this issue

<b>SAN FERNANDO VALLEY SIGHTING WAVE, 1979</b> . . . . .	<b>3</b>
By Walter H. Greenawald	
<b>UFOs AND PROPHETIC RELIGIOUS MOVEMENTS</b> . . . . .	<b>7</b>
By Mark L. Moravec	
<b>REVIEW OF THE MORAVEC PAPER</b> . . . . .	<b>10</b>
By Barry H. Downing	
<b>NET NEWS</b> . . . . .	<b>11</b>
By David L. Dobbs	
<b>BRIEF REPORTS</b> . . . . .	<b>12</b>
<b>HUNTER SIGHTS UFO IN NORTHERN CALIFORNIA</b> . . . . .	<b>13</b>
By Paul Cerny	
<b>FIELD-INDUCTION MAGNETOMETER</b> . . . . .	<b>14</b>
By G.A. Pennington	
<b>MOVE REVIEW ("Hangar 18")</b> . . . . .	<b>16</b>
By Barbara Mathey	
<b>IN OTHER'S WORDS</b> . . . . .	<b>19</b>
By Lucius Farish	
<b>DIRECTOR'S MESSAGE</b> . . . . .	<b>20</b>
By Walt Andrus	
<b>MOVIE REVIEW ("Hangar 18")</b>	

The contents of The MUFON UFO JOURNAL are determined by the editor, and do not necessarily represent the official position of MUFON. Opinions of contributors are their own, and do not necessarily reflect those of the editor, the staff, or MUFON. Articles may be forwarded directly to MUFON.

Permission is hereby granted to quote from this issue provided not more than 200 words are quoted from any one article, the author of the article is given credit, and the statement "Copyright 1980 by The MUFON UFO JOURNAL, 103 Oldtowne Rd., Seguin, Texas" is included.

# SAN FERNANDO VALLEY UFO SIGHTING WAVE

## JULY & AUGUST 1979

By Walter H. Greenawald  
(MUFON Field Investigator)

In early August 1979, I became aware of a singular UFO sighting in Canoga Park, Calif., reported in the San Fernando Valley Chronicle August 2nd. I contacted Sandy Sand at the paper inquiring if other UFO sightings had been noted. Publication of this event apparently led to other UFO witnesses stepping forward, although cautiously in some cases, and reporting other occurrences. Ultimately, this contact resulted in my interview and subsequent involvement in this small sighting wave.

The UFO events uncovered were mainly in the Canoga Park and Reseda area of the San Fernando Valley, a highly residential suburban area approximately 25 miles NW of Los Angeles. Through the cooperation of the Chronicle and the witnesses themselves I was able to gather information on 12 sightings (See Table). These events are spotted on a map showing relative locations.

In two cases I have corroborating evidence from independent witnesses who stated that they did not know of the other party. After an article in the Chronicle August 9th, Shari N. called me and volunteered her story about a seemingly innocuous NL which she saw in the same time frame as the Childers on July 25. During our initial discussion she admitted to a time lapse and some strange physiological effects. After I explained what may have happened she agreed that at least one regressive hypnosis session was in order. Generally, excellent cooperation was obtained from most witnesses ... only one family requested anonymity. Most other witnesses did not mind if their names were used in connection with their UFO sighting.

Three cases appear to have high validity and merit:

- \* C Childers NL 7/25/79 3 to 4 a.m.  
D Shari N. NL 7/25/79 3:15 a.m.

Arrangements have been made with an experienced psychologist, skilled in hypnotic regression, and at least one session will be attempted to determine the possibility of an abduction.

- \* H Peacock NL 8/3/79 9:15 p.m.  
I Palmer NL 8/3/79 9:15 p.m.

Corroboration of events from these two independent witnesses, unknown to each other and at significantly different sites, make this an excellent sighting. The fine report turned in by Mrs. Palmer allowed an estimate of size and altitude of the object to some degree of precision.

- \* E Pearson DD 7/25/79 7:15 a.m.

The multiple witnesses at one location plus the two unknown policeman make this an interesting DD case. More investigative effort will be done when time permits to learn the identity of the two officers. The police, if they know anything, are not cooperating.

One IFO resulted ... Mrs. Nancy Zabka after reading the article in the August 16th Chronicle phoned me and gave me this account. At 10 p.m. on the 18th of August she was in her backyard and noted a strange arrangement of lights toward the SW horizon. She called others in the family to watch. They all could hear a noise like a helicopter but couldn't make out the light pattern. Several days later she was discussing this event with a neighbor who also observed the phenomena but at a different vantage point ... it turned out to be a special sign aboard a helicopter spelling out a congratulatory message over a house in Hidden Hills, an exclusive housing development adjacent to the Zabka's.

As a result of this moderate and local sighting flap I was interviewed by the Chronicle and have agreed to author a weekly UFO column for as long as the interest is there on the part of the readers. At least there will be a local reporting center for UFO sightings if only temporary.

Efforts will continue in a cautious evaluation of the sighting of Shari N. as there appears to be the possibility of an abduction.

### Childers Sighting - C

Location: Canoga Park, Calif.

Date: 25 July 1979 3:00 to 4:00 a.m.  
(Night)

Witnesses: Dean Childers, 19 and a student at Pierce College; Mrs. Mickey Childers, mother and housewife; Another family member who prefers anonymity.

Sighting: Mrs. Childers was awakened by barking neighborhood dogs and got up to check on the disturbance. From her bedroom window (2nd floor) she saw a white glowing mass low in the sky over the Chatsworth Reservoir (N to NE) ... looking like a sparkler. She awakened her son, Dean, and both went outside and watched the device for some time with binoculars and a low-powered refracting telescope from the backyard. Initially, the object appeared to be close with an apparent size of 3/16". No sound.

Some time later the object rose to about 45 degrees elevation where the family watched for about 25 minutes. During this time frame they noted red, green, and blue blinking lights on the object, which appeared to climb to the E from a NNE direction. (Note: there is a scintillating star in the northern sky at about this position and at the

*(Continued on next page)*

(San Fernando, continued)

right time of morning.) The object continued to climb to 15,000 - 20,000 feet and then disappeared. Initially it appeared to be a white glowing spherical object.

Dean reported three incidents which occurred after or during the end of the major sighting. He saw somewhat peripherally three separate flashes like meteorites ... bright orange things off to the E each only lasting three seconds, about 5 minutes apart. It is not known whether these incidents were related to the major UFO seen.

Shari N. Sighting - D

Location: Canoga Park, Calif.

Date: 25 July 1979

Time: 3:15 a.m.

Duration: Several minutes

Witness: Shari N. (Due to the possibility

of an abduction, she shall remain incognito at least temporarily)

Sighting: As Shari N. was driving south on Topanga Canyon at 3:15 a.m. and shortly before she came to the light at Plummer, she became alarmed at what appeared to be an airplane about to crash. Whatever it was, it was close and appeared to be hovering, no motion one way or the other. She sketched three fuzzy and adjacent white spheres.

As she stopped at the light at Plummer St. she further studied the object. She even rolled the driver's window down but could hear no noise. Noting that there were no other cars around and that there seemed to be a lack of street lights and housing tract illumination, she became alarmed and ran the red light and went home.

During my interview the following abnormalities have emerged:

- \* She arrived home approximately 1/2 hour late - her husband was waiting up for her and wondered where she had been. (Shari is a cocktail waitress in a western saloon in Chatsworth and normally the trip home takes 12 to 15 minutes; this time it was 45 minutes)
- \* She felt nauseous for several days after
- \* She noted large water blisters on the insides of her knees
- \* Her western hat was on the seat next to her in the car - normally she holds it in place with pins as customers try to pull it off (she uses the hat also to hold her braid wig in place).

Shari is amenable to regressive hypnosis, commenting that whatever happened during that missing half

SAN FERNANDO VALLEY SIGHTING FLAP; JULY-AUGUST 1979

Date	Time	Location	Category	Witnesses	Description	
A	7/21/79	9:30-10:00 p.m.	Simi Valley	NL	Perez family (5)	Glowing white ball with blinking colored lights, whirring noise.
B	7/25/79	2:00 a.m.	Canoga Park Bassett & Vanowen	NL	4 Unknown Teenagers	Large white light making several passes, lit up ground.
C	7/25/79	3:00-4:00 a.m.	Canoga Park Platt & Saticoy	NL	Childers family (3)	Large white glowing mass with colored lights.
D	7/25/79	3:15 a.m.	Canoga Park Topanga & Plummer	NL *	Shari N. (1)	Impending air crash, physiological effects, time lapse.
E	7/25/79	7:15 a.m.	Canoga Park Oso & Saticoy	DD	Pearson & 6 others (2 police)	Metallic hovering cylinder. No noise.
F	7/25/79	11:00 p.m.	Woodland Hills Fallbrook & Dolorosa	NL	Hetman family (2)	White lights, possible electromagnetic effect.
G	8/3/79	12:10 a.m.	Reseda Victory & Tampa	NL	Mortillaro (2)	Saucer with blinking lights on bottom.
H	8/3/79	9:15 p.m.	Reseda Runnymede & Rhea	NL	Peacock (1)	Large red sphere with small white lights at bottom.
I	8/3/79	9:15 p.m.	Canoga Park Corbin & Lanark	NL	Palmer (1)	Large red sphere with feathery bottom.
J	8/4/79	8:30 a.m.	Canoga Park Oso & Saticoy	DD	George (1)	Same thing seen by Pearson on 7/25, different direction, witness not talking.
K	8/4/79	10:35 p.m.	Canoga Park Sherman Way & Milwood	CE-I	Artura (2)	Close approach of saucer, two humanoids seen in clear bubble at top.
L	8/24/79	3:20 a.m.	Canoga Park Sherman Way & Royer	NL	Anapol (1)	Close approach of pinkish/violet disk.

\* Possible CE-III - regressive hypnosis recommended



(San Fernando, continued)

"I then sped all the way home, hoping it would be there so my husband could see it. I also kept watching the light. I drove into the driveway, got out of the car, walked back to the sidewalk and looked to the north ... it was still there. I ran into the house, called my husband but he was in the tub and couldn't come out. I went outside and it was still there. Then I ran into the house for my binoculars but I still could not see anything but a big red light. So then I watched it without binoculars. I noticed something silver or grey drop slowly from it, but just for a short distance. Almost immediately the red light went off and on several times, the object then moved very swiftly to the NE; the light went off and it was gone. I watched a few seconds longer but could not see it. I have never seen anything like it."

Mrs. Palmer estimated an apparent size at  $\frac{1}{4}$ " and an elevation angle of 60 degrees. From this I calculated that the diameter of the object was approximately 80 feet and that it was at an altitude of about 8,000 feet. The location of the object (i.e., over Corbin at Lanark) is corroborated by the direction stated by Mrs. Peacock who lives about one mile to the east of Mrs. Palmer. Neither lady claimed that she knew the other so we can rule out complicity.

Mrs. Palmer called Channel 4 (NBC) who said that they also had several other calls on UFOs that night. No follow-up was done in this area due to the large number of calls being received at the Chronicle and at home.

#### Pearson Sighting - E

Location: Canoga Park, Calif.

Date: 25 July 1979

Time: 7:15 a.m.

Witnesses: Ira Pearson, retired carpenter; Ejnar Anderson, retired; George \_\_\_; Peter Kim, employee at Alta-Dena Dairy store; Two unidentified policemen in a cruiser.

Sighting: Ira Pearson was apparently the first to note the cylindrical UFO in the western sky at 7:15 in the morning. Soon, all three of his retired buddies at

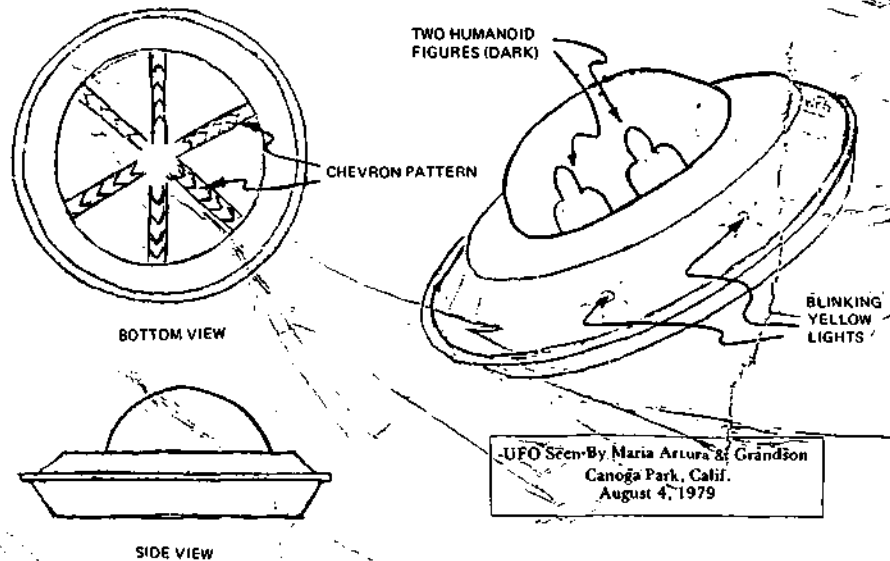

the same address noted the object. They all described it as reflecting sunlight, apparently metallic, and tilted on its side. Two witnesses did not agree as to whether the ends were rounded or square. Pearson looked at it with binoculars; he reported that it had square ends and was at 45 degrees. When it left, it tilted so that the axis was vertical, then disappeared to the west. Azimuth was 270 degrees, elevation angle was 45 degrees. Duration 5 minutes. No noise was detected.

Two policemen pulled up in a cruiser and proceeded to watch apparently through binoculars. Several witnesses thought that they were taking pictures, but Peter Kim who was close to them said that they had binoculars. Several phone calls from the reporter at the Chronicle were made to local police departments, but no details were made available as to who the two policemen were.

#### Artura Sighting - K

Location: Canoga Park, Calif.

Date: 4 August 1979

Time: 10:35 p.m.

Duration: 5 to 10 minutes

Witness: Mrs. Maria Artura (60)

Sighting: As Mrs. Artura was babysitting her grandson, Brian Berstein, age 6, she was summoned by the lad talking about a strange thing in the sky. Approaching from Topanga Canyon Blvd. in the west, she noted a round and saucer shaped craft with a plastic dome on top. Inside, she said, were two humanoid creatures with over-

sized heads. No clear details of the humanoids were noted, and she described the craft as shown in the attached sketch. No noise was noted as the craft approached and seemed to hover above the apartment building across the street, within several hundred feet or even closer. Mrs. Artura said that the saucer tilted to one side, straightened up (horizontal), then flew behind a tree directly across the street, stopped, tilted the other way. The craft flew off to the west. Weather was clear and warm. Both witnesses were very scared. A neighbor, Mrs. Pettengill, and three other witnesses also had a purported UFO sighting from their back yard in the same time frame.

Citizens Against UFO Secrecy (CAUS; P. O. Box 4743, Arlington, VA 22204) has filed a set of lawsuits against three federal agencies to obtain government documentation on UFOs. The suits - filed in U.S. District Court for the District of Columbia on June 24, 1980 - seek to obtain information from the National Security Agency, the Defense Intelligence Agency, and the Federal Aviation Administration. Paperwork accompanying the lawsuits suggests that the United States Attorneys are attempting to place the case with a judge whose rulings have previously been favorable to the federal government. Spearheading the drive for citizen access to government UFO information is lawyer Peter A. Gersten of the law firm Rothblatt, Rothblatt & Seijas.

# UFOs AND PROPHETIC RELIGIOUS MOVEMENTS

By Mark L. Moravec

A prophetic religious movement is a system of beliefs and practices, held collectively by a group of people, which "formalizes the conception of the relation between man and his environment" (Winick's definition of religion, 1961, p.454) and predicts the renewal and improvement of the world at some forthcoming time. By examining three ethnographic examples of prophetic religious movements, I will present the evidence for the view that such movements have several common elements and are more than simply religious attempts to escape from reality based on misguided prophecies. Rather, the movements seem to emerge as a response to both certain social conditions and an "impulse" within human consciousness pushing human beliefs in a definite direction to produce social change.

The Ghost Dance religious movement of the North American Indians emerged with great impact in 1890 after a Paiute healing shaman called Wovoka ("the Cutter") had a vision of God who ordered him to establish the new movement.

All Indians must dance, everywhere, keep on dancing. Pretty soon in next spring Great Spirit come ... All dead Indians come back and live again ... When Great Spirit comes this way, then all the Indians go to mountains ... Then while Indians way up high, big flood comes like water and all white people die, get drowned. After that, water go way and then nobody but Indians everywhere and game all kinds thick. -Wovoka, the Paiute Messiah (Brown, 1970, p. 416).

Despite the imprisonment of Ghost Dance prophets and persecution of their followers by the white men who thought the movement dangerous, it expanded to the most distant regions of the northwestern United States. (Lanternari, 1963).

The cargo cult of the Usurufa, who lived in the area around Kainantu

in the eastern highlands of New Guinea, was investigated by Robert Berndt in the 1950s when contact between the Usurufa and Europeans had still been minimal. The first contact was in 1930 when the natives were initially terrified by the sight of aeroplanes but later believed "the white men inside the big mother bird were friendly spirits". (Christiansen, 1969, p. 28).

Because the Europeans had red skins, they were not identified as men, but rather as spirits of the dead, returning with wealth in the form of quantities of European goods (cargo) which would be stored in the large warehouses the Usurufa had constructed. However, as the goods did not arrive as calculated, distrust of the Europeans grew. (Christiansen, 1969). The movement peaked in 1947 between Mount Hagen and the Markham River and spread beyond, with periods of disappointment and depression following excited expectation. (Lanternari, 1963).

A modern counterpart is a movement which began in the 1950s in an industrialized city in the midwest of the U.S.A. A suburban housewife, "Mrs. Marian Keech," received messages via automatic writing claimed to be sent by "superior beings from a planet called 'Clarion'. These beings have been visiting the earth in what we call flying saucers." (Festinger, Riecken and Schachter, 1964, p. 30). Through Mrs. Keech's network of friends, a movement of initially several dozen people gathered around her and became committed to the beliefs of the group's accumulating folklore. Possible objective, physical manifestations which occurred include the mysterious appearance and disappearance of a "stiff-legged entity" at a prophesied flying saucer landing.

The "Guardians," as the beings came to be known, gave the group

teachings and advice about religious matters and cosmology, and predicted future events, the most important event being a flood which would submerge the city just before dawn on December 21, accompanied by a cataclysm which would submerge the West Coast of the Americas. Those people who drowned would be spiritually reborn on other planets appropriate to their spiritual development, but flying saucers would come down from the sky in time to save the believers from the flood. Despite the fact that the disasters did not come to pass, the failed prediction reinforced the movement's conviction, because its members took credit for the avoidance of the destruction! The group only disbanded when the leaders were threatened with legal action and possible commitment to a mental hospital.

## Common Elements

The above three prophetic religious movements share a number of common elements. They --

- (1) were dissatisfied with the social conditions which they were forced to accept;
- (2) rejected established authority;
- (3) were initiated after a prophet received revelations and prophecies from a "higher being";
- (4) were promised a new age of enlightenment and renewal for the world, a rebirth in paradise; and
- (5) were catalyzed by individuals acting as leader, prophet and/or messiah.

By 1890, Indian culture was rapidly declining due to the unjust takeover of land and violent expulsion of the Indians by the white man. Wovoka's claim that the promised land was only for the Indians openly paved the way for the Sioux uprising. In New Guinea, the Usurufa's brief contacts with Europeans revealed the comparative materi-

(Continued on next page)



### (Prophetic, continued)

al disadvantage of the natives. According to Christiansen (1969, p. 108), the cargo cult is a "cult of wealth which does not merely embrace material goods, but also power, good fortune and fertility, etc., which has its roots in the traditional ideology." A study by Guiart and Worsley (Christiansen, 1969) found that, of 73 Melanesian cargo cults, only half had a belief in the cargo myth proper. In fact, according to this view, the cargo movements reflect more than an envious desire for European goods; they are a search for "spiritual cargo." The modern flying saucer movement was clearly unconcerned with material gain, refusing all offers of money. The cult members were unsatisfied with the social and spiritual conditions of modern, industrialized society. The Guardians communicated with Mrs. Keech to teach her and other humans "those principles, ideas and guides to right conduct that are necessary to advance the spiritual development of the human race ..." (Festinger et al, 1964, p. 45). The Usurufa cargo cult came to regard the Europeans as a threat to safety when the cargo failed to arrive, and rifles appeared in the villages. The flying saucer cult maintained its beliefs in the face of social pressure from the media and the legal authorities.

The revelations which initiated the movements all have a similar content. "God instructed Wovoka to command his people to work assiduously, not to steal, lie or fight, to love one another and to live at peace with the white man, even though they might still hope and pray for his disappearance from their midst." (Lanternari, 1963, p. 152). The revelation promised the Indians the return of a Golden Age of plentiful buffalo and spiritual salvation. Through dreams and visions with the Spirits/Europeans, an era of freely available material and spiritual wealth was prophesied for those in the cargo movement. For those in the flying saucer movement, paradise was to be their spiritual rebirth on planets with a higher level of spiritual development. The ghost dance and cargo movements also promised the return to life of the dead ancestors. As these

details show, all three movements include beliefs identical to some of the beliefs of Christianity. In fact, Wovoka was identified as the Son of God by the Mormons in 1892; and the most important Guardian, called Sananda, revealed himself to be the contemporary identity of Jesus Christ. Some Melanesian cargo cults constructed "telegraph stations" using dummy poles and "lines" of lianas to receive messages from Christ. Did these movements borrow Christian-like beliefs from the society they were rebelling against or did these beliefs evolve independently? It may be that the identity of Christ was incorporated into an independently evolved belief system which already included a Christ-like messianic role.

The "prophet" announces the forthcoming state of paradise, the "leader" directs the movement, and the "messiah" is believed able to make the millennial dream come true because of his divine powers (Christiansen, 1969). Wovoka, whose powers of healing were widely regarded, possessed all three roles and was probably a "charismatic" leader. Yet 20 years earlier in 1870, the prophet Wodziwob started the first version of the Ghost Dance after receiving a revelation emphasizing the same major themes of the return of the dead, the catastrophic end of the world, and the regeneration of Indian life after the disappearance of the white man. Dr. Berndt's last survey of the Usurufa cargo cult in 1953 revealed the movement still existed, being kept alive by a succession of prophets. The flying saucer cult gained a second prophet when one of its members went into a fit and trance and relayed communications to the group from the "Creator."

What these details of a succession of prophets point out is that the role of the prophet/leader/messiah, no matter how charismatic he or she may be, is limited. Lanternari (1963) suggests there is a dialectical relationship between the prophets and certain sociological and cultural conditions. The individual prophet is not the sole cause of the movement, but a catalyst around which the group centers.

### Theories of Causation

How do prophetic religious movements come about? Lanternari (1963) has suggested that many movements result from the clash between two cultures. The "less advanced" people may become aware of their economic and social lags and turn to the message of hope and salvation offered by the prophets (and it may well be European exploitation and oppression within the traditional contact which promoted the search for an alternative). In contrast, Oosterwal (Christiansen, 1969) believes that in the case of the cargo cult, the movement is traditional. It was only after the introduction of European goods that the concept of material cargo was incorporated into the belief system. Unless "we assume a completely static historical situation it is not unreasonable to suggest that movements rather like Cargo movements were occurring in Melanesia before the white man came there." (Burridge, cited in Christiansen, 1969). Thus, while a clash of cultures may emphasize material and social differences adding impetus to a movement, this clash may not be a basic cause of it. Studies of movements prior to substantial Western contact should support this conclusion, but few, if any, such isolated movements exist these days.

According to "deprivation" theory, the prophetic religious movement is only one of several responses to a state of deprivation — the despair caused by a dissatisfaction with present material and social reality when compared to the past or another culture. (Barber, in Lessa and Vogt, 1972). However, this theory doesn't explain why the prophetic religious movement is the response in those situations in which it has manifested.

It has been suggested that dissatisfaction with economic conditions is the cause of the movements. According to Lawrence's (1964) study of a cargo cult in Medang, New Guinea, there was an obsession for cargo because of economic necessity and because it was an index of self-respect and status. This observation does not seem to generalize to other movements. Certainly the members of the

## (Prophetic, continued)

flying saucer cult wanted nothing to do with material gain.

Vallee (1976) proposes that movements such as the flying saucer cult come into being in response to a mechanism, possibly within human consciousness, which is pushing human beliefs from a materialistic-oriented perspective to some level of higher awareness. This change in belief, in turn, produces cultural change.

Applying Vallee's hypothesis to the cargo cults, there is on the surface a contradiction presented by the belief in cargo. However, if we accept the hypothesis presented earlier, the cargo belief extends beyond solely material goods, which may have been emphasized only after European contact with the accompanying appearance of Western goods. Perhaps our materialistic Western perspective has also over-emphasized the importance of material cargo in the cult belief system.

The effect of prophetic religious movements is unambiguous: social change. But is this social change positive or negative? The movements often function to unify traditionally separate and hostile groups as has occurred with New Guinea cargo cults in a defensive reaction against the Europeans. This greater solidarity leads to a more effective development of the society (Christiansen, 1969). Lanternari (1963) views the movements as positive and progressive – paving the way for reform in the cultural, political, and social structure of society. Cohn (1961) views the movements as abnormal and negative and compares them to Hitler's nazi movement. In any case many authors are guilty in assuming that cultural change must follow the same pattern as that of Euro-American society. Although individuals in a movement face persecution and disappointments, could an ultimate benefit lie in the impact of prophetic religious movements on human consciousness?

### A Conclusion

Prophetic religious movements are vehicles for cultural change. The basic causes are probably both internal and external – an impulse within human

consciousness launching a "new" belief system in a situation where there is dissatisfaction with current social conditions. The movements are catalyzed by successive prophets yet manifest a system of beliefs consistent over time and geography except for minor local variations according to the history and environment of the society.

Hence prophecy is not merely a foresight of trouble or a gratuitous form of error, but the means by which an impact is made on the collective consciousness of the people, thereby leading to cultural change. The movements are not just religious attempts to escape from reality. Their myths and dreams are "not something that exists outside the world of reality, but represent a sort of truth and reality which, although differing from what we call reality, are not for that reason less true or less real ..." (Burridge, cited in Christiansen, 1969, p. 91).

### ... Some Questions

Anthropologists and sociologists do not know everything about the movements we have been discussing. Our conclusions can only be tentative and several unresolved issues remain. What is the nature of the "impulse" within human consciousness which might initiate the movements? Vallee (1976) thinks it originates from the "collective unconscious" – Jung's concept of a universal level of the human unconscious which is the residue of all our ancestral experiences. The potentialities of these ancestral or archaic images can enter consciousness as "thought-feelings" or archetypes: the irrational patterns of thought and primitive feelings found in dreams, visions, and myths (Hadfield, 1974). According to this line of thought the UFO is an archetype (see Jung, 1969). Yet Jung's "collective unconscious" is merely a theoretical construct and quite possibly scientifically unprovable. The point is that we may be attempting to explain one unknown (the UFO) in terms of another (the archetype). (Similarly, no one has proved that extraterrestrial life exists).

It seems pretty certain that prophetic religious movements have always been around in one form or an-

other. Specifically, will UFO cults continue appearing? As Jacobs (1975) relates, the 1950s saw the growth of hundreds of contactee and contactee-orientated clubs in the U.S.A. The early 1970s bred a "new" type of contactee, such as Uri Geller, who claims possession of psychic powers derived from UFO contact experiences. It seems that the prophets of the flying saucer cults will be with us for quite some time.

Is the contactee experience separable from the remaining UFO picture? Alvin Lawson (1977) has been conducting some very interesting investigations of the reliability of hypnotic regression in CE-III cases. He suggests that UFO abduction cases have "a wholeness or integral quality (although details and duration vary) which differs from other close encounters" which are frequently interrupted by human intrusion. It could be, and has been, argued that the "full-blown" religious contactee experience is different from the abduction cases (the latter being somehow more acceptable, especially to supporters of the extraterrestrial hypothesis). Yet both the religious (willing?) contactees and the abduction contactees go for rides in "flying saucers", receive esoteric cosmic philosophies, and often subsequently experience seemingly parapsychical experiences. In any case, it is important to find out whether or not the contactee experience is qualitatively different from other (more physical?) UFO experiences, since a difference may imply multiple causation (despite Occam's Razor) or, at the very least, a multiple approach (physical and parapsychical) to solve the entire UFO mystery (I use the term "parapsychical" to cover both psychological and apparently parapsychological events). In one sense, the UFO problem reminds me of the apparent paradox of the electron being both a particle and a wave. The UFO phenomenon, in totality, appears to be both physical and parapsychical. Any proposed solution of the UFO mystery cannot ignore either the physical events at Socorro or the parapsychical events experienced by Mrs. Keech and her followers.

(Continued on next page)

But we must not forget the people who actually go through the prophetic religious experience. The prophets who receive their psychic revelations may undergo a personality change from ordinary people to those with the "inner glow" brought on by religious conversion. They and their followers are compelled to follow a radical and complete belief system. But this is often at the cost of personal distress and sometimes tragedy brought on by the experience itself and the subsequent persecution by the rest of society. In the movement centered around Mrs. Keech, several of the core members quit their jobs several weeks before the predicted disaster — which never occurred. One of the most highly educated in the movement, a local professor, was to say: "I've had to go a long way. I've given up just about everything. I've cut every tie. I've burned every bridge. I've turned my back on the world. I can't afford to doubt. I have to believe. And there isn't any other truth ... This is a tough time but we know that the boys upstairs are taking care of us." (Festinger et al, 1964).

Prophetic religious movements are not the delusions of "backward natives." They are occurring today, in our own "highly developed" society. At the height of the flying saucer cult, the members received literally hundreds of visitors, telephone calls, and letters from seriously interested people. Their ideas were not without popular appeal.

#### REFERENCES

- Brown, Dee, *Bury My Heart At Wounded Knee*, London: Barrie and Jenkins, 1970.
- Christiansen, Palle, *The Melanesian Cargo Cult: Millenarianism as a Factor in Cultural Change*, Copenhagen: Akademisk Forlag, 1969.
- Cohn, Norman. *The Pursuit of the Millennium*, NY: Harper, 1961 (2nd ed.).
- Festinger, Leon; Riecken, Henry W.; Schacter, Stephen. *When Prophecy Fails*, NY: Harper & Row, (1956), 1964.
- Hadfield, J.A. *Dreams and Nightmares*, London: Penguin, (1954), 1974.
- Jacobs, David M. *The UFO Controversy in America*, NY: Signet, 1976.

Prophetic religious cults involving UFOs have for some time been an embarrassment to the scientific study of UFOs. Scientists have tried to separate themselves from the "cult fringe."

Mark L. Moravec's article should help take away some of our fear of the prophetic religious aspect of UFOs. He has shown that when people are in a state of deprivation, a cult of salvation often develops, sometimes stimulated by contact between a lower and higher society (Africa and Europe in regard to the Cargo cults, the American Indians and Europeans in regard to the Indian Ghost Dance Movement).

We live in an age of fear and anxiety, especially in the face of the destructive potential of technology. Moravec's paper shows that sociology and anthropology predict that UFO reports, in so far as they are thought to be a superior power, would automatically trigger hopes for salvation especially from deprived groups.

So, scientists should not look at the cult side of UFOs as something we should try to hide in a closet. Rather, anthropological studies seem to pre-

dict that if a higher form of reality were to appear in our skies, prophetic cults around their reality would develop. And they have.

From my own particular perspective in regard to Biblical studies, let me add these words of caution. The Biblical religion believes in a world of prophets: false and true. Thus, although the prophets in Moravec's study all produced false prophecies of a flood, the Bible maintains the view that Noah was a prophet who called the shot on the nose.

The meaning of this caution is that in our scientific approach to the prophetic religious cults, our temptation may be to say that while the cults are worthy of study, we cannot expect much truth to emerge from them. Beware that among all those cult groups, there may be a Noah.

It is possible that UFOs are caused by a higher reality, one that we might even call Divine. And this divine reality may indeed have its prophets.

Good science is always open to the unlikely, though of course it is rightly skeptical of the unlikely.

- Jung, Carl G. *Flying Saucers: A Modern Myth of Things Seen in the Sky*, NY: Signet, (1959), 1969.
- Lanternari, Vittorio, *The Religions of the Oppressed*, NY: Alfred A. Knopf, 1963.
- Lawrence, Peter. *Road Belong Cargo*, Manchester: Manchester University Press, 1964.
- Lawson, Alvin H. What Can We Learn From Hypnosis of Imaginary "Abductees"? *The MUFON UFO Journal*, Nov. 1977, No. 120, 7-9.
- Lessa, W. & Vogt, E.Z. *Reader in Comparative Religion*, NY: Harper & Row, 1972.
- Vallee, Jacques. *The Invisible College*, NY: Dutton, 1976.
- Winick, Charles. *Dictionary of Anthropology*, Paterson, NJ: Littlefield, Adams & Co., 1961.

The "International UFO Reporter" of the Center for UFO Studies, previously absorbed in the newsstand magazine *Probe*, now will be incorporated in *Second Look* magazine — a Washington, D.C. based publication dealing with UFOs and extraterrestrial life as well as some other borderline science subjects. *Second Look* is intelligently edited, has an attractive format, and has a circulation of about 11,000, so we applaud this effort by the Center for UFO Studies to reach a wider audience. (*Second Look*, bi-monthly, \$15 per year, 10 E Street, S.E., Washington, D.C. 20003)

# NET NEWS

## "Project Redlight"

By David L. Dobbs, K8NQN

### AMATEUR RADIO UFO NETS

NET NAMES	MHz	DAY	TIME	N/C	QTH
MUFON 40-Meter	7.237	Sat. A.M.	0800 EST/EDT	N1JS	MA
MUFON 75-Meter	3.977	Sat. A.M.	0800 CST/CDT	WA9ARG	IL
Cincinnati Area	28.795	Thurs. P.M.	0100 UTC	KA8BVO	OH
Saturday Afternoon	28.795	Sat. P.M.	2000 UTC	KA8BVO	OH
Harrisburg Area	144.250	Fri. P.M.	0000 UTC	WA3QLW	PA

Although summer seems to have reduced activity on local UFO amateur radio nets, the MUFON nets continue to flourish. A dozen check-ins are usual on the 40-meter section, and four or five on the 75-meter net. Recent UFO sightings in upstate New York were reported on the early section run by Joe Santangelo, N1JS, MUFON's Amateur Radio Director, by KB2DP, Winnie. Her feminine voice is a welcome change on the net, and cuts nicely through the seasonal background of lightning static. Anomalous nocturnal light sightings have been frequent over North Carolina, according to Ray, K4HXC, although little is being reported from other parts of the country. An analysis of reports in that state shows an increase of 100% over last year. About 25% of the cases were daylight sightings, and most of the UFO activity has been along fault lines.

One mystery often leads to another. Such has indeed been the case with the UFO movie shown by the Air Force to select groups of radar specialists during the 1950's. Len Stringfield's report of this movie was described in an article, "Hams on the Trail of UFO's," published in the April 1980 issue of *73 Magazine*. Shortly after reading it, an amateur operator with a fascinating story checked into the 40-meter net to contact the author. Although his subsequent disclosure is still under investigation, Journal readers may be able to supply additional information which would be helpful.

Matt Archer, as we will call him, runs an electronics business today in a small midwestern town. From 1961 to 1963, he performed radio maintenance at the Atomic Proving Ground. He also did some top-secret radio work for the Air Force at times. "Area 51" was located 60 miles due east of the base camp, behind a mountain range which separated it from Yucca Flat. Under highest security, an operation was conducted there under the code name PROJECT REDLIGHT. Archer presented a body of evidence strongly suggestive that this project involved flight-testing of a UFO which had been shipped there from Edwards Air Force Base.

The craft was not conventionally powered, but flew silently. Radios in good operating condition often "just died for no reason," only to begin working again as suddenly. Although security men always escorted him inside and out of view of the runway whenever IT, as they referred to the craft, was about to take off or land, he heard no engine noise of any kind. Once he saw the craft on the ground at a distance of about half a mile. It was 20 to 30 feet in diameter, he estimated, and pewter-colored, lacking any wings or tail.

A friend of Archer's was a radar operator at a station near Tonopah, Nevada. He confided that he often observed UFOs over the test site, but was told to ignore them. One was described which crossed the screen completely

in three revolutions of the antenna, an extraordinary velocity.

All work on this project stopped suddenly in 1962. Archer remembers reading an article, in *Reader's Digest*, he believes, which described a UFO exploding over eastern Nevada after crossing the U.S. from the east coast. He assumed that it might have been the craft being tested, since the date given in the article was around the time when PROJECT REDLIGHT came to a halt. As yet, this article has not been substantiated, however, Archer also believes that the craft he saw may have been the undamaged UFO shown in the Air Force movie, which intelligence sources cited in the Stringfield disclosure said had been recovered after crashing in New Mexico in 1952.

Archer was familiar with the turbojet fan-driven experimental disc tested at nearby Nellis Air Force Base during this period. Coincidentally, this was pictured on the front cover of *The MUFON UFO Journal* for February 1980. This was not the craft he observed, nor would it have flown silently, if indeed it had flown. He thinks that this "non-flying saucer" may have been a cover-up for the real UFO research being conducted in Area 51.

Shortly after Len Stringfield was able to confirm privately the existence of Area 51 and its possible connection with UFO research, *Newsweek* publi-

(Continued on next page)

# BRIEF REPORTS

*(Sightings from various sources containing features of special interest)*

March 8, 1980; Wilmington, N.C. at 9:30 p.m. a UFO (no description) swooped down over the car of a local businessman, made a jet-like sound, and cast a brilliant white light on the car. The driver's small dog began howling as if the sound were hurting its ears. The driver, thinking the object was going to crash, got out of his car. The UFO hovered overhead for 5 to 10 seconds longer before it took off and disappeared. (Tarheel UFO Study Group Newsletter, North Carolina, July 1980. Case #21-80)

March 24, 1980; Baterias, Mendoza Province, Argentina. Personnel from YPF (government oil fields) who had been involved in previous UFO sightings were among numerous witnesses to a luminous object with a small dome on top that flew over Baterias. The technical workers of YPF said that one of their members was hospi-

talized with a nervous breakdown as a result of the sighting. (From La Razon, Buenos Aires, Argentina, March 28, 1980. Translation by Jane Thomas)

March 31, 1980; Bari, Italy. A young Mexican acrobat and the son of an Italian circus owner sustained visible burns when they were confronted by a circular UFO emitting a very intense light. Next morning they noticed the effects. Felipe Garcia, 19 (the Mexican) had a burn on his wrist beneath his watch, which had mysteriously stopped. Paride Orfei, 17, had burns on his waist under his cowboy belt. (ANSA news service, La Razon, Buenos Aires, Argentina, March 24, 1980. Translation by Jane Thomas)

April 10, 1980; Lincolnton, N.C. A businessman saw a bright red disc-shaped object directing a beam of light onto the ground as if searching for something. Finally it moved away at a 45 degree angle making a strong humming sound and leaving some kind of exhaust streak. This was at 9:30 p.m.

At the same time in Lincolnton, two communication center personnel saw a red ball-shaped UFO moving horizontally at tree-top level above highway 321 south of town. (Tarheel UFO Study Group Newsletter, June 1980 Case #13-80 and 13-A-80)

April 20, 1980; San Mateo, California. While driving north on I-280 about 5:30 a.m., Richard A. Jokinen, an electrical engineer, and his 18-year-old son saw five bright metallic spheres flying rapidly along the length of Crystal Springs Reservoir. They appeared to be about 500 feet above the water, and made no sound. They were seen against the backdrop of coastal mountains and traveled about 120 degrees of arc in about 5 seconds. Toward the end of the sighting, the objects appeared to have Saturn-like rings around their circumference. (Investigated for MUFON by Thomas Gates, Space Science Center Planetarium Director. Preliminary report)

May 7, 1980; Valdese, N.C. About 5:20 p.m. while driving east on I-40, an X-ray technologist first experienced car radio interference and then saw a UFO move below a cloud cover directly in front of her car. The object made a horseshoe turn and banked, showing the shape of an upside down soup bowl with a dome on top and a red rectangle on the underside. At one point the car radio blacked out completely. The UFO disappeared towards South Mountain after about 5 minutes, appearing hat-shaped as it departed. (Tarheel UFO study Group Newsletter, June 1980. Case #19-80)

## (Net News, continued)

cized it in their issue of May 12, 1980. The team sent to rescue the hostages held by Iran had practiced for its mission, they reported, "at Nevada's top-secret Area 51, a 50-square mile quadrant of Nellis Air Force Base"!

For 18 years, Matt Archer has been seeking an explanation of what actually went on during PROJECT REDLIGHT. He hopes that Freedom of Information Act probing or corroboration by other witnesses will bring out the true story, which has been briefly summarized here. Until that happens, it remains, of course, only an unsubstantiated but highly interesting tale.

Unfortunately, not every Saturday session of the MUFON nets leads to such information. Aside from the fellowship and keeping up to date about happenings in the UFO field

which checking in regularly engenders, the amateur radio nets definitely accomplish something of substance even during periods of low UFO activity, as this story confirms.

News of MUFON activities in the San Antonio area and an occasional message from Director Walt Andrus is relayed from Elmer, WA5CTJ by Dr. Will Armstrong, W0NC; in St. Louis. W0NC is also a mainstay of the 75-meter net and acts as liaison between the two sections.

With the return of cooler weather and resumption of indoor activities, it is anticipated that contact with the West Coast and southwestern part of the country will once more be practical on 10 meters. For this reason, we have listed the information on all UFO nets known to be active. Amateurs interested in UFOs and related subjects are welcome to check into any net, whether they have any information to transfer or not.

~\*~

Journal readers (except commercial enterprises) are invited to submit requests for information, UFO items for sale, and offers of information exchange for publication. Name and address will be published on request, but if you prefer anonymity we will code your request and relay responses on a confidential basis. MUFON, 103 Oldtowne Road, Seguin, Texas 78155.

# HUNTER SIGHTS UFO IN NORTHERN CALIFORNIA

By Paul Cerny  
(MUFON Western Regional Director)

A large object hovered silently over a nearby tree late at night. Various colored lights went on and off and blue vapor came from side exhaust ports. It changed from a silhouette to an object so brightly lit that he could hardly see its shape. This happened not once, but three times in 1973. So reported Dave McCready, associated with the Air Force for over 30 years.

Dave had been in the Air Force from 1942 to 1945. He then worked as Assistant Fire Chief for Travis Air Force Base, Calif., for another 28 years, including 5 years in the Azores.

Though he lived in Vacaville, Calif., he and his family owned property south of Dinsmore in northern California. Dinsmore is in Humboldt County, 50 miles east of Fortuna, 120 miles west of Red Bluff on Highway #36, and 75 miles west of Platina. The town is a small lumber community with a gas station, country store, and a bar.

Their piece of land, approximately 3 miles south of Dinsmore, had been private property and most of the timber had been harvested by 1975. The terrain is hilly, with a ravine, and is sparsely covered with trees. They had a trailer situated there and often used it as a hunting camp. Nearby was a 1100 Watt generator to service the refrigerator and lights for the trailer, providing some convenience for tired hunters.

On this particular September in 1973, Dave and five friends were camped on the site in the trailer. About 10:30 p.m. he stepped outside and immediately noticed a beam of white light shining on the tallest tree — an "old snipe" which was across a ravine and about 200 to 250 yards from him. An "object" was hovering silently over the tree. Dave was quite familiar with the terrain. The hill on the left sloped down gradually to the right, with random trees along the crest and

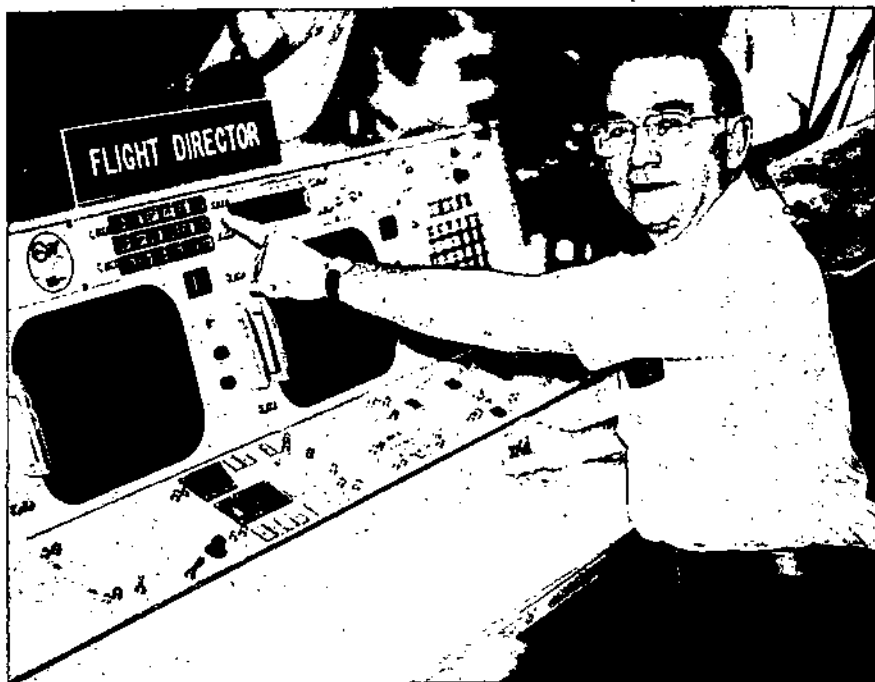

Paul Cerny during NASA Mission Control Tour, 1980 MUFON UFO Symposium.

the big tree down hill. The object was 75 to 100 feet above the trees, with a light beam shining from the lowest edge down onto the tree. The defined beam was about 4 or 5 feet wide and was definitely not a spotlight. The light, he judged, was just plain white — not a high-intensity light.

The light then went out and the dome-shaped outline of the craft was revealed by its silhouette. A line of eight or ten blue jets suddenly appeared as if on an even platform, looking like exhaust ports, similar to a blue exhaust from an airplane — continuous.

About 10 to 15 seconds after the single beam of light on the tree went out, he noticed a bar of dim light in the shape of an inverted angle on the surface of the dome. The two ends, starting from the base of the dome, diagonally, met at the top center of the dome. In about fifteen seconds the angled bar of light went from dim to

very bright, all one light, he noted, filling in the area. Then it decreased in intensity, faded and went out, and he could see better.

Suddenly the lower beam of light came on again, moving over the surface area of the tall tree, not in a wide angle — just moving around the tree. It went through this repeating procedure, the lightbeam faded and the angled bar of light came on dimly. There appeared to be a sequential pattern and he knew what to look for the second time on the exhaust ports. Did they go off or stay on all the time? He wasn't sure, because, in the bright intensity of the light on the dome, he could hardly see the exhaust. He was fascinated, watching the strange procedure from this unknown object.

He watched as the object completed the second sequence of events

*(Continued on next page)*

## FIELD-INDUCTION MAGNETOMETER

By G. A. Pennington

(Project VISIT, P. O. Box 877, Friendswood, TX 77546)

and began a third time. By then he was watching closely. He moved back and forth, 20 or 30 feet each way — 50 feet altogether — looking at it from different vantage points. He realized that perhaps he was seeing a UFO. It wasn't anything like any aircraft the military had, he was positive, based on his experience in the Air Force. He was aware that there seemed to be no noticeable sound, possibly because he was standing near the 1100 Watt generator.

Moving from one side to the other of where he had originally sighted the light, he watched it closely as it went through the "sequence" a third time. He wished the rest of the men were there with him. He ran to the trailer, pounded on the door, and yelled to the men to come out, that he wanted to show them something unusual. They came running out the door and followed him to the spot. There was nothing! It was gone — absolutely gone! No sign of anything. Possibly his yelling and pounding had alerted the object of impending danger.

The next day they crossed the ravine to examine the tree and the terrain. They found nothing on the ground and apparently nothing had happened to the tree, at least nothing that was apparent. Strange that this hovering object, at least 40-50 feet across and 12-15 feet high, would leave no evidence of having been there, and he had no witnesses, as well as no answers. He related the experience to his family, but told no one else. Strangely enough at about that same period of time there were multiple objects sighted over the city of Vallejo, where Dave lived with his family in their home. Forty or more people, Dave noted, were involved this time, including police officers. But they were not as close as 200 feet.

He thought little more about it until 4 years later when he and his wife were watching a television show on the subject of UFOs. Suddenly he said to his wife, "That's what I saw! That's exactly what I saw!" It was an illustration on the TV as seen by a man named Bill Pecha from Colusa, Califor-

Over the past several years, many UFO incidents have been accompanied by magnetic disturbances which affect compasses, automobile tape decks, aircraft instruments, etc. In an effort to detect and render these effects more visible for analysis, various types of sensing devices have been proposed and in some cases used in a limited manner by UFO researchers. In general, these devices work by recording changes in the local geomagnetic field which occur during UFO passage.

Since changes in the geomagnetic field are the basis for operation of some of these detectors and hence UFO detections, it is appropriate to consider the changes which can be expected by natural causes. In a paper presented by William H. Hunkins at the 1971 Midwest UFO Conference, it is stated that deviations over 5% are rare for even the most extreme naturally caused transient disturbances, such as magnetic storms linked with solar activity. Utilizing his numbers of 50,000 to 60,000 gammas for the geomagnetic field, this 5% deviation would amount to approximately 3,000 gammas. Now for most cases, the fields in question can be considered to obey the inverse cube of the distance from the source relationship with respect to field intensity. Hence, distance rapidly attenuates the field effects and localizes any disturbances.

Obviously, from the above discussion, very sensitive instruments such as proton free precision magnetometers would be required to detect disturbances from a great distance. However, since it has been suggested by other UFO researchers that a UFO field is on the order of as much as 100,000 gam-

---

ma. Since then he has thought a lot more about his sighting of that still unidentified flying object.

Contacting this investigator was the next step, resulting in this interesting report of a close encounter by a reputable witness.

mas, good results can be obtained using inexpensive homebuilt magnetometers as described herein. In addition, though less expensive, the field-induction magnetometer is faster than a proton magnetometer by a factor of about 1,000.

Shown in Figure 1 is a field-induction magnetometer designed to have its sensor mounted vertically on the exterior of a building. The actual sensor is comprised of a 61 cm. long mu-metal (or soft iron alloy with equivalent magnetic permeability) bar that serves as a flux concentrator for two wire coils. The larger of the two coils (L1) is a 16 KHz horizontal oscillator coil slipped over the bar and positioned at its center. It should be pointed out that other types of coils may be used as long as they contain greater than 5,000 turns of wire. The effect of a smaller number of turns will directly affect the sensitivity of the detector. As designed here, changes of 1,000 gammas in the geomagnetic field can be detected if local conditions permit.

The second coil (L2) consists of 30 turns of No. 24 enamelled wire insulated from and wound over the main coil. Coil L2 is used to induce a voltage across L1 for testing. Signals induced across L1 are amplified by OA1. OA1 is a standard 301A operational amplifier. When the TEST switch S1 is depressed, capacitor C1 discharges through potentiometer R3 and Coil L2, inducing an EMF in main sensing coil L1. Potentiometer R2 is used to adjust the sensitivity threshold. The amplified signal is indicated on meter M1. It should be noted that if the geomagnetic field variations produced by a UFO also vary in flux density at some constant frequency  $f$ , a steady-state EMF will be induced in proportion to  $f$  and M1 will continually register. Because the magnetic field characteristics for UFOs are still largely unknown, it is recommended that the instrument

be initially operated in the PEAK mode as discussed later in this paper.

The signal at the output of OA1 is also passed via TRIGGER LEVEL potentiometer R7 to the gate of SCR1. When SCR1 fires, it activates alarm A1. Since the power source is dc, A1 will remain on even after the triggering signal has passed. Normally closed RESET pushbutton S4 must be momentarily depressed to silence the alarm. It should be noted that the alarm will continue to be activated repeatedly if the detected object is still present.

Two modes of signal detection are provided by PEAK/NORMAL switch S2. In the NORMAL mode, meter M1 will continuously show the signal value output from OA1 when the detected object is present (if UFO flux is variable) and will return to null afterwards. In the PEAK mode, the strongest output level from OA1 will remain displayed on meter M1 until the charge on capacitor C3 leaks off. For this reason C3 is selected to provide for the best low leak characteristics. The charge can be dissipated on C3 at any time by momentarily selecting the NORMAL mode. Two scales are provided on M1 for OA1 output level, so as to provide increased granularity of the detected signal due to large or small field variations induced in L1. These scales are selected by HI/LO switch S3.

Operating power is obtained from a line operated, regulated 12 volt dc supply. If line power should fail, B2, a back-up 12.6 volt battery supply will operate the unit. Silicon diodes D3 and D4 provide for keeping the battery voltage slightly lower than the regulated power supply voltage and thus allow its use only if line power should fail. The unit is turned on via ON/OFF switch S5. LED will illuminate when power is applied via the regulated power supply only, as it would quickly aid in draining B2 when in battery-only operation. TRIGGER LEVEL control R7 should be set to prevent the alarm from being triggered by natural or man-made sources in close proximity to the detector.

The construction and packaging of the instrument is not especially critical. The flux concentrator and coils can be protected by a length of magnetically neutral plastic pipe. Although

## FIELD INDUCTION MAGNETOMETER

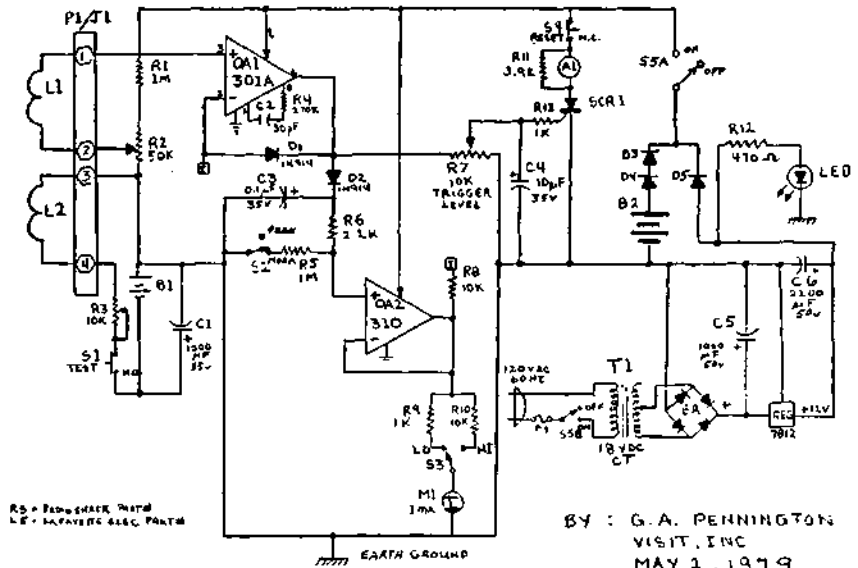

Figure 1

only the type of flux concentrator rod mentioned above has been tested, other rods may be used at a reduced sensitivity as long as the magnetic per-

meability of the rod substance is fairly high (greater than 5,000). A list of part numbers for a major retailer will be supplied on request to simplify construction of the instrument.



Left to right: Len Stringfield, Tom Deuley, and Richard Hall at Fund for UFO Research table, 1980 MUFON UFO Symposium. (Photo: Bruce Deuley)



# "HANGAR 18"

(Sunn Classics Pictures, Salt Lake City, Utah)

At the annual MUFON meeting in June, Mildred Biesele told us to watch for "Hangar 18," a fictional film about a captured UFO. She had spoken with the Sunn Classics office, who told of Sunn asking the Air Force if they could shoot the movie on an air force base. The answer was such a violent "NO!" that they felt they had touched a sensitive spot. However, they discovered an abandoned air force base at Big Spring, Texas, and the film was made on location there. "You wouldn't believe the roadblocks put in the way of production by the Air Force," said Sunn. "Hangar 18" opened on the west coast in August, and will be released throughout the rest of the country in January. Mildred also provided me with a list of the actors, who are not big stars but do a fine job. I am grateful for her help.

Straightforwardly told with no artistic frills, the movie is packed with excitement and suspense, and I enjoyed every minute of it. Briefly, three astronauts launching a satellite encounter a UFO. One does not survive. Radar at NASA traces its flight to the southwest United States. It is an election year, and as soon as the President and his advisor are informed that the Air Force is in possession of a flying saucer they decide to stop at nothing to hush up the event and keep the news from the public. The astronauts realize they are being manipulated and their lives ruined, so, taking matters into their own hands, they rush to locate the craft and prove its existence to the world, thus saving their honor and demonstrating the truth. Meanwhile the machine and its occupant, hidden on an air force base in Hangar 18, are being examined by a team of experts. Their discoveries and amazingly rapid deductions (after all,



© Sunn Classics Pictures, Inc. All rights reserved.

**HANGAR  
18**

THE UFO'S SECRETS™ (TM) & Hangar 18™ (TM) are trademarks of Sunn Classics Pictures, Inc. All rights reserved. The UFO's SECRETS™ (TM) & Hangar 18™ (TM) is a registered trademark of Sunn Classics Pictures, Inc. All rights reserved. The UFO's SECRETS™ (TM) & Hangar 18™ (TM) is a registered trademark of Sunn Classics Pictures, Inc. All rights reserved.

this is a movie) alternate with the ruthless pursuit of the heroes (astronauts) by the villains (FBI), and the action builds to a satisfactory climax.

A more explicit description would spoil your fun, but interesting questions arise from the thrills. Is the story based on a real incident or combination of incidents, and if so which ones? Does any evidence exist that the Feds have been authorized to kill witnesses to shut them up, and that this has indeed been done? If so, who gave the order? Which President? Any comment on these points, or others, would be welcome.

It is evident that UFOs are now a popular subject, and we may expect some imaginative books and movies. Mildred reports that "The Ogden Enigma," just out, is a fictional tale based on a real UFO incident. As long as they announce themselves to be fic-

tion, as does "Hangar 18" ("any resemblance to actual persons or places is purely coincidental"), the public may not confuse the fictional with the actual, but since the subject is the way it is, no doubt confused concepts will result.

— Barbara Mathey

MUFON is working on a special report on UFO abduction cases, to include reports from 1971 through 1980. If you have case reports or newspaper references for this period, please submit them for this special project. All contributions will be acknowledged. Participants in the recent minipanel on UFO abduction cases, or others with similar professional credentials, are invited to contribute evaluative articles.

LIVINGSTON CO. PRESS, Howell, MI - March 26, 1980

Closely encountered

# UFOs return yet again to busy Fowlerville sky

Fowlerville

A UFO has again invaded the quiet skies over Livingston County. The latest reported sighting was at Marsh and Sober Roads, about 8 miles north of Fowlerville, shortly after 10 p.m. on the night of March 19.

Linda Hough was watching TV when she heard a loud sound outside, "like a noisy car," she says. "I looked out and there was a huge light in the sky above Marsh Road."

"I didn't have my contact lenses on so I took the binoculars outside to look at it better," she explained. "It was skimming along just above the trees and the light was so bright it lit up the sky."

Linda wanted to try to see the shape of the UFO so she went back indoors and put on her contact lenses. The object was still in the sky when she went back out.

"I watched it cruise along," she said. "I thought at first it was a plane, but there were three planes in the sky and one of them passed right over it, and the plane was so small" (in comparison) She described it as having a "whole bunch of lights, maybe some red ones, but the white lights were brighter." It reminded her of search lights and lit up the sky "like a glow." "I've never seen

anything like it in my life," she says.

She described the noise as "really loud, louder than a jet, and it vibrated the air."

Linda watched the object for about fifteen minutes, until it was almost out of sight, headed west toward Lansing. Then she realized how frightened she was and went inside and locked the doors. She was home alone with her young son. "I called my aunt next door to see if she had seen anything, but she had been asleep and my cousins weren't home. The neighbors on the other side weren't home either." Linda watched the sky until her husband came home from work a short time later. He hadn't seen anything in the sky and neither had Linda's parents when they returned home from a movie.

Does Linda Hough believe in UFOs?

"Yes, I believe in UFOs. I think there is something in outer space. I don't think they're threatening; they're just curious like we are. I think they're just curious about what is here on Earth as we are curious about all the other planets. They aren't here to hurt us," she says.

Anyone seeing a UFO should call the Livingston County Sheriff Department at (517) 546-2440.

JOURNAL, Muscatine, IA - March 21, 1980

# Weird light is sighted

By DAVE DeWITTE  
Staff writer

"It made the hairs stand up on back of my neck. I know somebody's up there looking down, and I'd like to know who it is."

Mrs. Fred Birch, who has a "gorgeous, panoramic" view of the Mississippi River from her home south of Keithsburg, may be more wary about looking outside from now on.

When she first glanced out the kitchen window at around 9 o'clock Thursday evening Mrs. Birch thought she saw a "funny bright light" and didn't think too much of it. But after her husband had left for his night-shift job, she noticed it was still there, and took a harder look.

"I said to my son, 'that isn't a star; it's got a goldish cast to it,'" Mrs. Birch recalls. Later she awakened her daughter to take a look at it, and telephoned neighbors.

What she saw hovering over Mapes Island in the Mississippi River was something gold, possibly with a red spot on it, about 3-4 times as bright as the brightest star visible. It hovered above the island for nearly an hour. "It would move a little to the right and a little to the left, but basically stay in the same spot," she said.

After about an hour, the light began lowering through trees on the island. "I

realized it was something quite different," she recalls. "If it had stayed there hovering I would have kept my mouth shut. I hope I never see it again."

Mrs. Birch was so captivated by what she thought she was seeing that she called neighbors. "I said, you know I don't drink, but I want you to look at what I'm seeing across the island and tell me what I see is there."

She called Mrs. Walter Wolfe, who saw it also. Their sons went down to the levee, where they watched the light move west across the Mississippi into Iowa. The boys used binoculars. They said many smaller lights resembling small aircraft could be seen in the sky also.

A part-time Keithsburg deputy reportedly saw the light, as did others although their accounts were not as complete.

Rock Island sheriff's authorities said a report March 11 came in at approximately the same time of night. Two teenagers, Julie Smith, rural Reynolds, and Michael O'Donnell, Andalusia, reported a very different looking object in the night sky.

The two were driving on a gravel road east of Reynolds when they saw something about as big as a two-car garage. The object, which was sketched by O'Donnell, was rounded on the bottom and squared off at the top.

A Rock Island County deputy who was on patrol the same night reported seeing a bright light in the sky "at about the same time."

OBSERVER, Charlotte, NC - May 12, 1980 CR: G. Fawcett

# More UFOs Reported In Carolina Skies

By WAYNE NICHOLAS  
Observer Gastonia Bureau

LINCOLNTON — George Fawcett, Lincolnton's 59-year-old unidentified flying object (UFO) expert, had planned to spend last Wednesday night resting.

Instead his phone rang off the hook. An x-ray technician, who didn't want her name used because she feared people would think she was crazy, had spent five minutes on her way home that afternoon, watching what she thought was a UFO maneuver around the Burke County skies near Val-dese.

"I was playing the radio and singing to the top of my lungs," the woman said, "when suddenly the radio got full of static."

The woman told Fawcett (and later a reporter) that she leaned over to hit the car radio to see if she could make it work. When she did, something red in the sky caught her eye. It was about 5:20 p.m. Wednesday.

She said she pulled her car off to the side of the road, looked again and saw a large, soup-bowl-shaped UFO hovering less than a mile away.

"It was about the size of a four-room house," she said.

The technician said the object didn't have any windows, but on the bottom was a large red rectangle, which looked larger than a door. "It was the color of a shining candy apple," she said.

She said she watched it slowly maneuver for about five minutes until it started to disappear in the distance.

"People are going to think I am crazy," she said over and over. "But I know what I saw."

Fawcett, who teaches a course in UFOs at the Lincolnton campus of Gaston College, says he's been swamped with new reports of flying saucers ever since April 29, when The Observer printed a story

asking people to notify him of unusual sightings.

Most reports have come from Gaston, Lincoln and Catawba counties, he said.

Pete Link and Jeff Schlatter, two Rutherford County carpenters, called Fawcett to report they were working on the roof of a house near Lake Norman at 9 p.m. April 24 when a bright object rose vertically in the sky, made a loop and disappeared.

Fawcett said UFO skeptics have said flying saucer reports increase dramatically whenever they receive publicity, but Fawcett, who has studied flying saucer reports for 30 years, says that's not always true.

Studies have shown that people see UFOs regularly with or without publicity, he contends.

"All the articles do is to get people who would normally be hesitant to talk about their experiences to come forward," Fawcett said.

Fawcett, who is doing a paper on the reactions of people to UFO reports, said people who see flying saucers may run into difficulty from their friends when they tell what they've seen.

"Some people actually get mad when you tell them you've seen a flying saucer," Fawcett said.

And that's one of the reasons he wants people to call or write him about their experiences.

He promises a sympathetic ear.

## Seen A UFO?

If you spot what you think is a UFO, George Fawcett would like to know about it. Contact him after 6 p.m. at (704) 735-5725, or write him at 602 Battleground Road, Lincolnton, N.C. 28092.

JAPAN TIMES, Tokyo, Japan - March 4, 1980

## CR: Y. Matsumura Soviet Press Criticizes Flying Saucer Cult

MOSCOW (AP) — The Soviet press renewed its attacks Sunday on Soviet flying-saucer enthusiasts, insisting that no scientific evidence has confirmed purported sightings of interplanetary visitors or their spaceships.

The national daily Pravda devoted nearly a half-page to debunking UFO rumors, including rumors that the Soviet Academy of Sciences publishes "special research volumes" — presumably in secret — about UFOs.

The paper, quoting a reader's letter, also cited underground "UFO reports" that circulate in typewritten form in the Soviet Union.

The reader said the report he saw — entitled "Are We Alone in the Universe?" — claimed to quote "reliable sources" in scientific and government organizations.



Mark R. Herbstritt

# Astronomy Notes

## THE SKY FOR AUGUST 1980

**Mercury** — Early in the month, it can be seen low in the east just before sunrise. By the 26th it is in superior conjunction.

**Venus** — It is well placed among the "winter six" constellations in the morning sky, rising about 3½ hours before the sun, and standing about 37 degrees above the eastern horizon at sunrise. Greatest elongation west (46 degrees) occurs on the 24th.

**Mars** — In Virgo, it can be seen low in the southwest, just after sunset, but is rather unfavorably situated for nor-

thern observers. It passes 2 degrees north of Spica on the 17th.

**Jupiter** — Though technically an evening "star," it is too close to the sun to be seen.

**Saturn** — It is very low in the west at sunset.

The Perseid meteor shower occurs from the 10th to the 14th.

### Moon Phases:

Last Quarter — August 3 at 7 a.m. (EST)

New Moon — August 10 at 2:09 p.m. (EST)

First Quarter — August 18 at 5:28 p.m. (EST)

Full Moon — August 25 at 10:42 p.m. (EST)

## THE SKY FOR SEPTEMBER 1980

**Mercury** — Though technically an evening "star," it is too close to the sun to be seen.

**Venus** — A classic favorable elongation: it rises about 4 hours before the sun, and by sunrise it stands about 40 degrees above the eastern horizon, above Regulus and below Castor and Pollux.

**Mars** — Moving from Virgo into Libra, it is very low in the southwest at sunset and sets about 2 hours later.

**Jupiter** — It is too close to the sun to be seen, conjunction occurring on the 13th.

**Saturn** — It is too close to the sun to be seen, conjunction occurring on the 22nd (E.S.T.)

### Moon Phases:

Last Quarter — Sept. 1 at 1:08 p.m. (EST)

New Moon — Sept. 9 at 5:00 p.m. (EST)

First Quarter — Sept. 17 at 8:54 a.m. (EST)

Full Moon — Sept. 24 at 7:08 a.m. (EST)

Last Quarter — Sept. 30 at 10:18 p.m. (EST)

### (Director's Message, continued)

at the 1980 MUFON UFO Symposium in Clear Lake City, Texas, on June 7th titled "UFO Contactees: Captive Collaborators or Cosmic Citizens" and also "UFO - '79" in San Diego, Calif., on November 17, 1979. His paper is included in the 1980 MUFON UFO SYMPOSIUM PROCEEDINGS available from MUFON. A limited number of copies of the Proceedings of the Rocky Mountain Conference on UFO Investigations are available for \$4.00 from Dr. R. Leo Sprinkle, Box 3708, University of Wyoming, Laramie WY 82071; telephone (307) 766-2187. We are all very proud of the fine work that Dr. Sprinkle has done in his specialized field.

Reginald Marquis, one of our Canadian members, has recently authored a new paperback in French titled *LES OVNIS: CEUX QUI LES ONT VUS* (211 pages), copyright 1980 by Les Enterprises, Castelriand Inc., C.P. 997, 9 Ste-Anne, Riviere-du-Loup, G5R 3Z5, Canada. Frequent quotations and references are made to the MUFON UFO Journal and various annual MUFON UFO Symposium Proceedings. A copy of his book may be

secured for \$7.00 by international postal money order by writing to Reginald Marquis, 47, Hotel-de-Ville, Casier postal 254, Riviere-du-Loup, Quebec G5R 1L4, Canada.

Another publication of interest to our French-language members is a small pamphlet (20 pages) titled "Detection du Phenomene Ovni en France" Resultats de l'Annee 1979 by Alexandre Laugier, Bureau: 6, Rue Des Tanneurs, 13100 Aix-En-Provence, France. It is a report and graphs on some of the work done by CNES-GEPAN in Toulouse, France. Please contact Mr. Laugier at the above address for further information if you desire a copy of this pamphlet.

After an 8-year absence from the UFO Conference scene, APRO has announced the sponsorship of a symposium to be held June 12, 13, and 14, 1981, in Cleveland, Ohio. Tentative speakers are R. Leo Sprinkle, Ph.D.; Stanton T. Friedman; Daniel Harris, Ph.D.; Peter Van Arsdale, Ph.D.; and John S. Derr, Ph.D. The selected theme for the Conference is "Are We Alone In The Universe?" Since some of the people who normally attend the

Annual MUFON UFO Symposia may also want to attend the APRO Conference, the 1981 MUFON UFO Symposium at M.I.T. in Cambridge, Mass. (Boston) will be held on July 24, 25, and 26, hosted by MUFON of Massachusetts. We are looking forward to having our first symposium in the Eastern Region in 1981.

Toronto, Ontario, Canada, will be the site for 1982 and Los Angeles, Calif., in 1983. Pittsburg, Pa., has expressed a serious interest in hosting the 1986 event. An established MUFON UFO group in a city or state is a prerequisite for submitting a bid to host an Annual MUFON UFO Symposium. Bids for 1984 and 1985 are open for qualified groups. Please contact your International Director for further information if you are seriously interested. For the past eleven consecutive years, MUFON has conducted annual UFO symposia, the only major UFO organization to sponsor these annual international events. We are proud to be the leader in this important contribution to UFOlogy and public education.

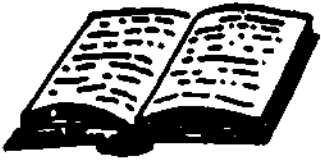

Lucius Farish

## In Other's Words

The July 22 issue of NATIONAL ENQUIRER reports that UFO sightings seem to be associated with natural disasters, such as earthquakes and volcanic eruptions. An article by Bob Pratt in the July 29 issue profiles Ted Phillips and his study of UFO landing trace cases. There have now been nearly 2,000 such cases in 64 countries. In some instances, the evidence suggests that objects weighing 8 to 10 tons (or more) have caused the traces. The August 5 issue outlines the research of Dr. Harold Heaton, who is studying cases involving animals' reactions to UFOs.

James Oberg's "UFO Update" column in the August issue of OMNI deals with the UFO sighting reports of Kenneth Arnold, who began the "flying saucers" uproar with his reported sighting in 1947. Arnold claims to have seen UFOs on other occasions since then, so this brands him a "repeater," according to Oberg, who quotes Dr. J. Allen Hynek as saying that so-called "repeaters" are "utterably unreliable." While it is probably true that Hynek made such a statement, that certainly does not mean that it should be accepted (by Oberg or anyone else) as being valid. Oberg also errs in saying that "all (Arnold's) UFOs looked the same." On the contrary, one of the nine objects reported by Arnold in 1947 was quite different from the other eight. His later sightings were of objects with varying descriptions. Oberg also reports on UFOs and the U.N., following the ouster of Grenada's former Prime Minister, Sir Eric Gairy.

Another Oberg article is found in the September issue of FATE. In this one, he "disposes" of various stories about UFOs on the Moon, enigmatic lunar formations, etc. While there has been a great deal of nonsense written on this topic (especially regarding astronauts and UFOs), it is easy to sense a bit of "overkill" in this attempt to write off some things which have genuinely puzzled lunar observers. The many reports of TLP (Transient Lunar Phenomena) contain details which are not so easily explained as natural phenomena.

The September issue of PROBE has an article by Dr. J. Allen Hynek, "The Legion of the Bewildered Silent," as well as Allan Hendry's "UFO Update" column. It is understood that PROBE has now ceased publication, which is not surprising, in view of the types of articles carried in recent issues. It is unfortunate that all the issues could not have matched the quality of the "Collectors Edition" which was released several months ago.

Anyone who has not yet obtained a copy of THE ZETA RETICULI INCIDENT by Terence Dickinson has missed some excellent information on the research done by Marjorie Fish on the "star map" allegedly seen by Betty Hill while on board an alien spacecraft. The publication is a reprint of Dickinson's 1974 article in ASTRONOMY magazine, along with all subsequent material published in that magazine which dealt with the article. Dickinson has now authored a four-page "update" on the map, which discusses the various criticisms by Carl Sagan and others. Both the booklet and update are available from Stanton Friedman at the following address: UFORI, Box 958, Houlton, ME 04730. The price is \$3.00 for both items. Well worth your time and money.

### UFO NEWSCLIPPING SERVICE

The UFO NEWSCLIPPING SERVICE will keep you informed of all the latest United States and World-Wide UFO activity, as it happens! Our service was started in 1969, at which time we contracted with a reputable international newspaper-clipping bureau to obtain for us, those hard to find UFO reports (i.e., little known photographic cases, close encounter and landing reports, occupant cases) and all other UFO reports, many of which are carried only in small town or foreign newspapers.

"Our UFO Newsclipping Service issues are 20-page monthly reports, reproduced by photo-offset, containing the latest United States and Canadian UFO newsclippings, with our foreign section carrying the latest British, Australian, New Zealand and other foreign press reports. Also included is a 3-5 page section of "Fortean" clippings (i.e. Bigfoot and other "monster" reports). Let us keep you informed of the latest happenings in the UFO and Fortean fields."

For subscription information and sample pages from our service, write today to:

UFO NEWSCLIPPING SERVICE  
Route 1 - Box 220  
Plumerville, Arkansas 72127

The 1981 MUFON UFO Symposium will be held at the Massachusetts Institute of Technology, Cambridge (Boston), Mass., July 24-26. This promises to be an intriguing and well-attended event in a region containing many veteran UFO researchers, including MUFON State Director Joe Santangelo, MUFON Director of Investigations Raymond Fowler, Walter and David Webb, Joe Nyman, John Oswald, Betty Hill, and many others. Make your plans now.

# DIRECTOR'S MESSAGE by Walt Andrus

"UFOs: A Canadian Perspective," chaired by Henry H. McKay, MUFON Regional Director for Canada, was an invitational conference held at the Metro-Toronto Reference Library, 789 Yonge St., Toronto, Ontario, on March 22, 1980. The theme or topic of discourse was directed toward current research, educational endeavors, and aspirational goals of organizations and individuals dedicated to scientific studies and a rational approach to Unidentified Flying Objects or related disciplines. An invitation to participate was extended to those people in southern Ontario who had demonstrated in the past an active concerned interest in this subject matter.

In Mr. McKay's introductory speech, he related that the UFOlogist as a researcher or field investigator is faced with many difficulties when dealing with a transient phenomenon and the attendant disciplines. Two such aspects were enlarged upon by Henry during his brief address, supported by a slide and pictorial display, which examined the need for a broader understanding as to the complexity of landing trace cases and the problems in resolving photographic evidence. These could be misinterpretations of common causes, a perpetrated hoax, or a true graphic display of a still unidentified anomaly captured on film. He recommended three books of divergent interest to the participants, two by Canadian authors; "The UFO Connection" by Arthur Bray residing in Ottawa; "UFO-Sightings, Landings and Abductions" by Yurko Bondarchuk; and W.H. Boward's "Operation Mind Control."

Other speakers were David Haisell, author of the paperback book "The Missing Seven Hours" and editor of the quarterly publication JOURNAL UFO, who outlined some of the work of U.P. Investigations Research, Inc., Mississauga, Ontario; Pat De la Franier, editor of TROFUS, a private newsletter

for the Stratford UFO Research Team, Stratford, Ontario, reported on their work; and Oscar Magocsi, author of the monograph "My Space Odyssey in UFOs" ... the true story of a Toronto man's first-hand encounter with space aliens.

Larry Fenwick and Joe Muskat, both officers of CUFORM, Inc. of WilLOWdale, Ontario, gave a presentation on the investigations of a reported encounter incident involving a number of local people. The publisher of RES BUREAUX BULLETIN, known as "Mr. X," outlined his experiences delving into and uncovering important documentation pertaining to Canadian government involvement. Mr. McKay and his colleagues are to be commended for conducting this one-day UFO Conference, whereby the participants could personally meet and share their investigative experiences in helping to resolve this perplexing enigma. All but two of the speakers are MUFON members.

Robert M. Hipp, State Director for Pennsylvania, has announced that Thomas Eveland, Box 4402 RD#4, Stroudsburg, PA 18360, is our new State Section Director for Monroe, Northampton, and Carbon counties. Mr. Eveland was recommended by Raymond Fowler, Director of Investigations. Tom is an environmental biologist with an M.S. in biology. Two new Research Specialists are Myron Karl Ilkin, 72 Manahan St., Bankstown, N.S.W. 2200 Australia, a physicist with a Masters in Applied Science and a member of UFO Research Australia, and Douglas J. Labat, 4801 Lurline St., New Orleans, LA 70127, an engineer with the telephone company in New Orleans who will be working with our State Section Director James J. LaChute.

STIGMATA, Number 10, Third Quarter of 1980, the publication devoted to reporting on the continuing investigation into the occurrences of

animal mutilations by Project Stigma, P. O. Box 1094, Paris, TX 75460, was recently mailed to subscribers by Tom Adams, MUFON State Section Director, and the world's leading investigator into these bizarre events. This issue places emphasis on the international scope of mutilations. The 1980 subscription price for four quarterly issues is \$5.00 and the same will apply in 1981.

MUFON member John Paul Oswald, of Hampton, N.H., has submitted a scholarly manuscript of 525 pages titled "UFOs and A Coherent World-view," copyright 1980, to your director for his evaluation and comments. John has done a magnificent job of expressing his personal views on this controversial subject and has made definite recommendations to existing UFO organizations as to their future action. John personally feels that the answers to the UFO phenomenon are contained in this manuscript. He not only reviews the status of UFOlogy today, but delves into the positive and negative aspects of Christianity and the UFO as a new perspective from the Bible and projected into the future. Since I haven't studied the entire manuscript, I am not qualified to evaluate Mr. Oswald's findings, explanations, and recommendations. The manuscript has had very limited exposure to date among the leaders in UFOlogy. It is one of the most comprehensive studies of this nature that your director has had the privilege of being exposed to.

We are indebted to R. Leo Sprinkle, Ph.D., for mailing a copy of the "Proceedings of the Rocky Mountain Conference on UFO Investigation" (contactee conference) conducted on May 23, 24, and 25, 1980, at the University of Wyoming. Dr. Sprinkle has shared the experiences of some of the participants in the paper he delivered

(Continued on p. 18)